



WELL MASTER
Produce more. Spend less.

XCEL™ SINGLE PAD

EXTENDED LIFE, SINGLE PAD PLUNGER

APPLICATIONS

- Designed for marginal wells and wells with low Gas-Liquid Ratio (GLR)
- Ideal for wells with tight spots and downhole restrictions
- Used where standard pad plungers experience high wear
- Excellent for low pressure and low liquid volume wells, where plunger weight is critical
- Designed to run through an x-nipple

FEATURES AND BENEFITS

- Machined tool steel pads for **precision mechanical seal**
- **Lower lifting costs** with high performance and longer wear life
- **Co-designed** by skilled and experienced Field Operators
- Standard design uses hardened tool steel and plated for **long life**
- **Pad wear indicators** at .015" and .030"
- Highly **articulated pads** allow for up to 128 degrees/100 ft. dogleg severity
- **Efficiently** runs through profile nipples and tight spots
- Stress relieved fishing neck **adds strength**

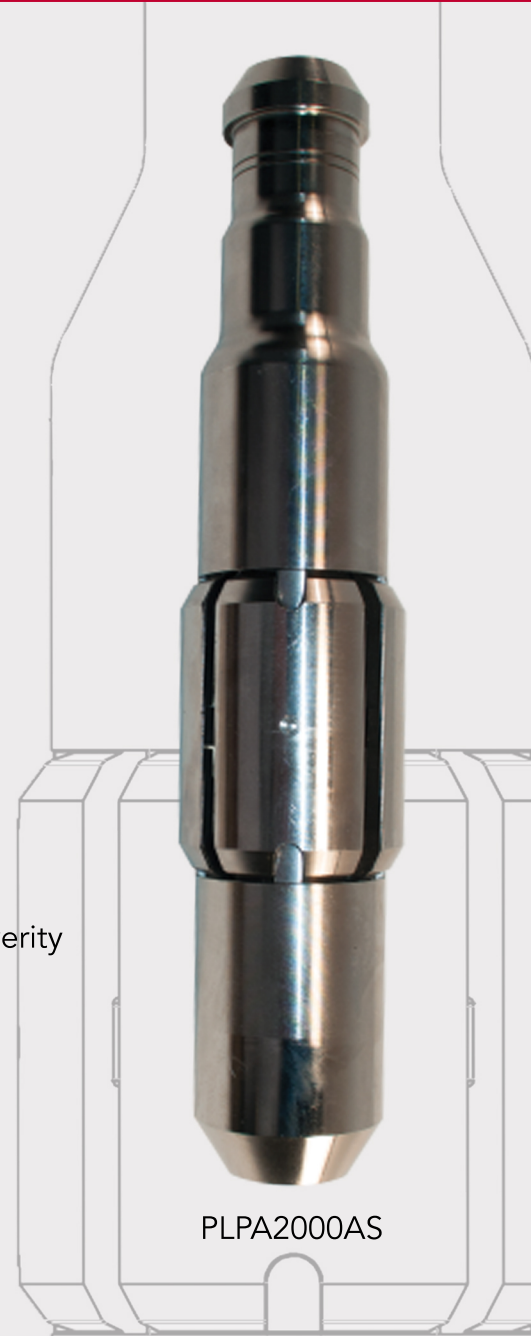

PLPA2000AS

TECHNICAL SPECIFICATIONS

Part No.	Outside Tubing Dia. (in.)	Nominal Inside Tubing Dia. (in.)	Nominal Tubing Weight (lbs./ft.)	Plunger Length (in.)	Nominal Plunger Dia. (in.)	Plunger Weight (lbs.)
PLPA2000AS	2 3/8	1.995	4.70	10.38	2.08	5.8
PLPA2500AS	2 7/8	2.441	6.40	10.99	2.53	9.0

Contact Well Master today to find out how we can optimize your oil and gas well production.

Call 303.980.0254 | Email info@wellmaster.com | Visit www.wellmaster.com
16201 Table Mountain Parkway, Suite 100 | Golden, CO 80403 | Fax 303.980.0355

©2022 Well Master Corporation, All rights reserved.