



WELL MASTER
Produce more. Spend less.

POGOTM PLUNGERS

SHOCK ABSORBING PLUNGERS

APPLICATIONS

- Used where no downhole stop or spring assembly is installed
- Effective against **paraffin, salt, and scale producing wells**

FEATURES AND BENEFITS

- Self-contained bumper spring eliminates the need for a downhole stop
- No-Go shoe has cutter to **remove salt, scale, and paraffin**
- **Economical solution** compared the conventional spring assembly
- Eliminates the need for servicing of downhole spring
- No downhole restriction of conventional spring

AVAILABLE IN TWO SIZES

- Solid body with patented high-life rib design (2 3/8" and 2 7/8")
- Xcel™ Dual Pad with oversize pads and extended life (2 3/8" and 2 7/8")

TECHNICAL SPECIFICATONS

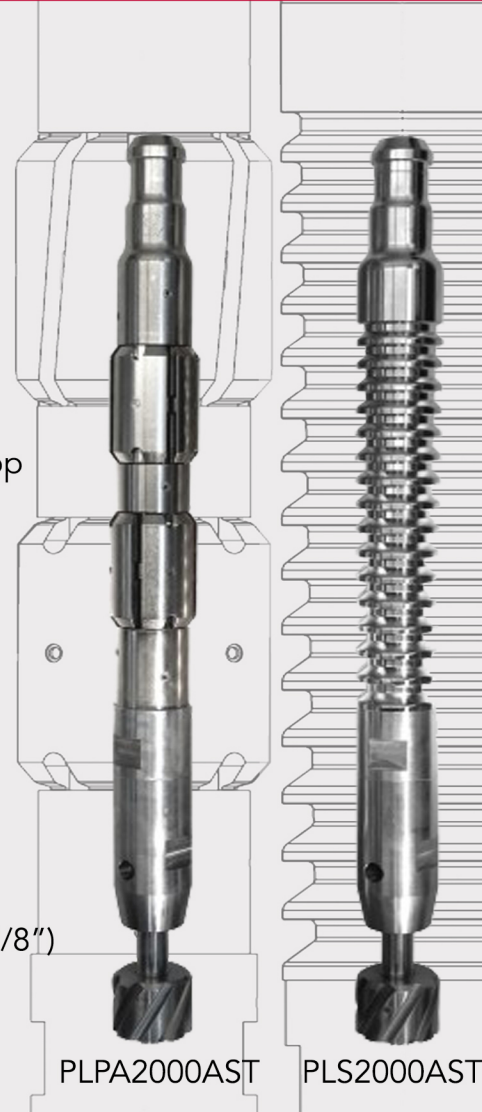

Part No.	Outside Tubing Dia. (in.)	Nominal Inside Tubing Dia. (in.)	Nominal Tubing Weight (lbs./ft.)	Plunger Length (in.)	Nominal Plunger Dia. (in.)	Plunger Weight (lbs.)
PLS2000AST	2 3/8	1.995	4.70	22.13	1.890	12.8
PLPA2000AST	2 3/8	1.995	4.70	21.50	2.080	12.2
PLS2500AST	2 7/8	2.441	6.50	22.25	2.340	17.0
PLPA2500AST	2 7/8	2.441	6.50	23.25	2.530	18.0
Materials of Construction:	Constructed of hardened and electroless nickel plated steel for sweet gas service					

PATENT INFORMATION

Protected under US Patent 8,162,053

Contact Well Master today to find out how we can help optimize your oil and gas well production.

Call **303.980.0254** | Email info@wellmaster.com | Visit www.wellmaster.com
16201 Table Mountain Parkway, Suite 100 | Golden, CO 80403 | Fax 303.980.0355